

TRIRO C6000

TRIPLE SCREW PUMPS



With decades of experience in designing and manufacturing rotary positive displacement pumps, SPX's Plenty Mirrlees Pumps have built an excellent reputation for reliable pumping equipment for the marine, oil processing, petrochemical processing, power generation, defense, sugar and general industries. With Plenty Mirrlees Pumps, SPX has a solution for most pumping applications with a range that includes two screw (TWINRO), three screw (TRIRO) and our 2000 series vane pumps incorporating the unique variable flow feature.

Based in Charlotte, North Carolina, SPX Corporation (NYSE: SPW) is a global Fortune 500 multi-industry manufacturing leader with over \$5 billion in annual revenue, operations in more than 35 countries and over 15,000 employees. The company's highly-specialized, engineered products and technologies are concentrated in Flow Technology and energy infrastructure. Many of SPX's innovative solutions are playing a role in helping to meet rising global demand for electricity and processed foods and beverages, particularly in emerging markets. The company's products include food processing systems for the food and beverage industry, power transformers for utility companies, and cooling systems for power plants. For more information, please visit www.spx.com.

Plenty Mirrlees Pumps - TRIRO C6000 Triple Screw Pumps

C6000 Series pumps are designed principally to handle clean lubricating liquids within the viscosity range of 33 to 15,000 SSU. The C6000 is part of the TRIRO family of pumps which include the T, E and H series.

PRODUCT BENEFITS AND FEATURES

- Silent, vibration, and pulse-free operation
- Type 7 insert interchangeable with Roper 6000/Plenty type 3, 4, 5 and 6 pumps
- Extremely low NIPr
- Ductile Iron or Fabricated Carbon Steel Casings
- Fully integral replaceable insert can be used without any additional Ductile Iron or Fabricated Carbon Steel Casings
- Gear motors not required. Designed to normally operate at motor synchronous speeds. Can operate up to 5000 RPM
- Insert reduces downtime and maintenance costs
- Pump can be quickly repaired without disturbing the outer casing or piping
- Same insert can be used in any of the horizontal/vertical casing & mounting options
- Normal lead (NL) and Short lead (SL) inserts are interchangeable



Ductile Iron 6300 with Flanged Ported Case

Typical product applications

MATERIALS OF CONSTRUCTION

- **Pump Casing** Ductile Iron (ASTM A536 65-45-12 or Fabricated Carbon Steel (ASTM A106)
- **Seal / Bearing Housing** Carbon Steel (ASTM A108 1020)
- **Cover Plate** Carbon Steel (ASTM A108 1020)
- **Insert Casing** Aluminum (ASTM A356)
- **Idler Bearing Bushing** Aluminum (ASTM 6082)
- **Screw Set** Power Rotor - Alloy Carbon Steel (ASTM A108 1040), Idler Rotors- Pearlitic Iron (ATSM A126 Class B)
- **Bearing** Single Row Sealed Ball Bearing
- **Shaft Seal** Single Mechanical Seal (Elastomer Bellows or Positive Drive)
- **Elastomers** Buna N - up to 210° F (100° C)
FKM - up to 250° F (120° C)
- **Gaskets** Asbestos Free Synthetic Fiber

MODEL IDENTIFICATION

C6 0 00

Example - **C6112**

00 = Displacement (Theoretical capacity) / 1000 RPM

0 = Case construction

- 1 = Ductile Iron / one piece NPT ported case
- 3 = Ductile Iron / two piece flanged ported case
- 5 = Fabricated steel case
- 8 = Insert only (no additional case)
- 9 = Flange mounted pump insert with Suction Flange

C6 = C6000 Series TRIRO triple screw pump

The C/J range is designed for medium pressure high flow applications on clean liquids.

Forced Feed

Lubrication

For machine bearings and gearing



Fuel Oil

Supply to boilers



Compressor Gland Sealing



Hydraulic Pump

For Elevators, Power Packs, etc.

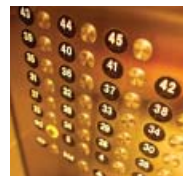

API Rotary Pump

Specification 676 and

API Forced Lubrication

Specification 614 and

many more.

THEORY OF OPERATION:

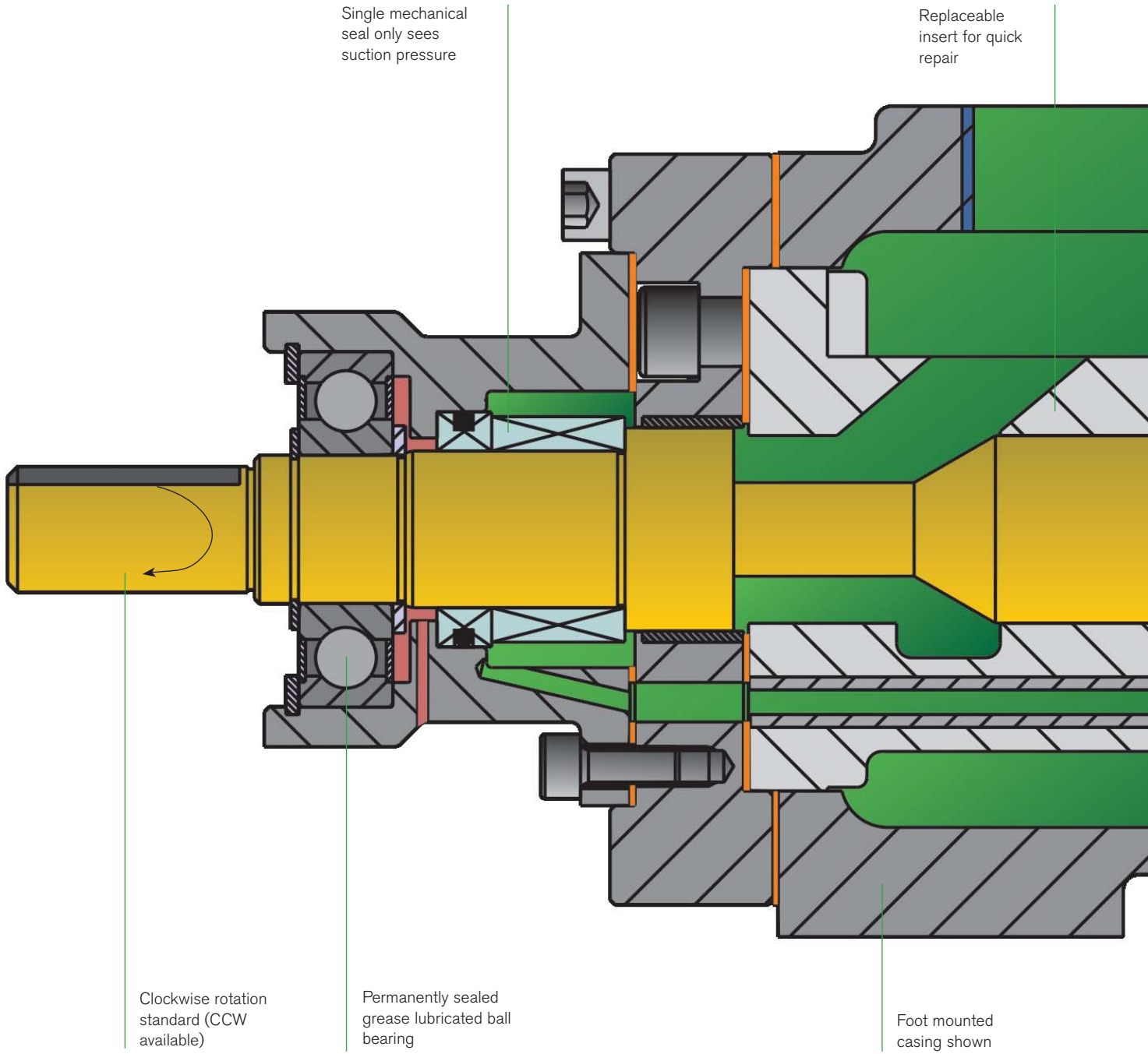

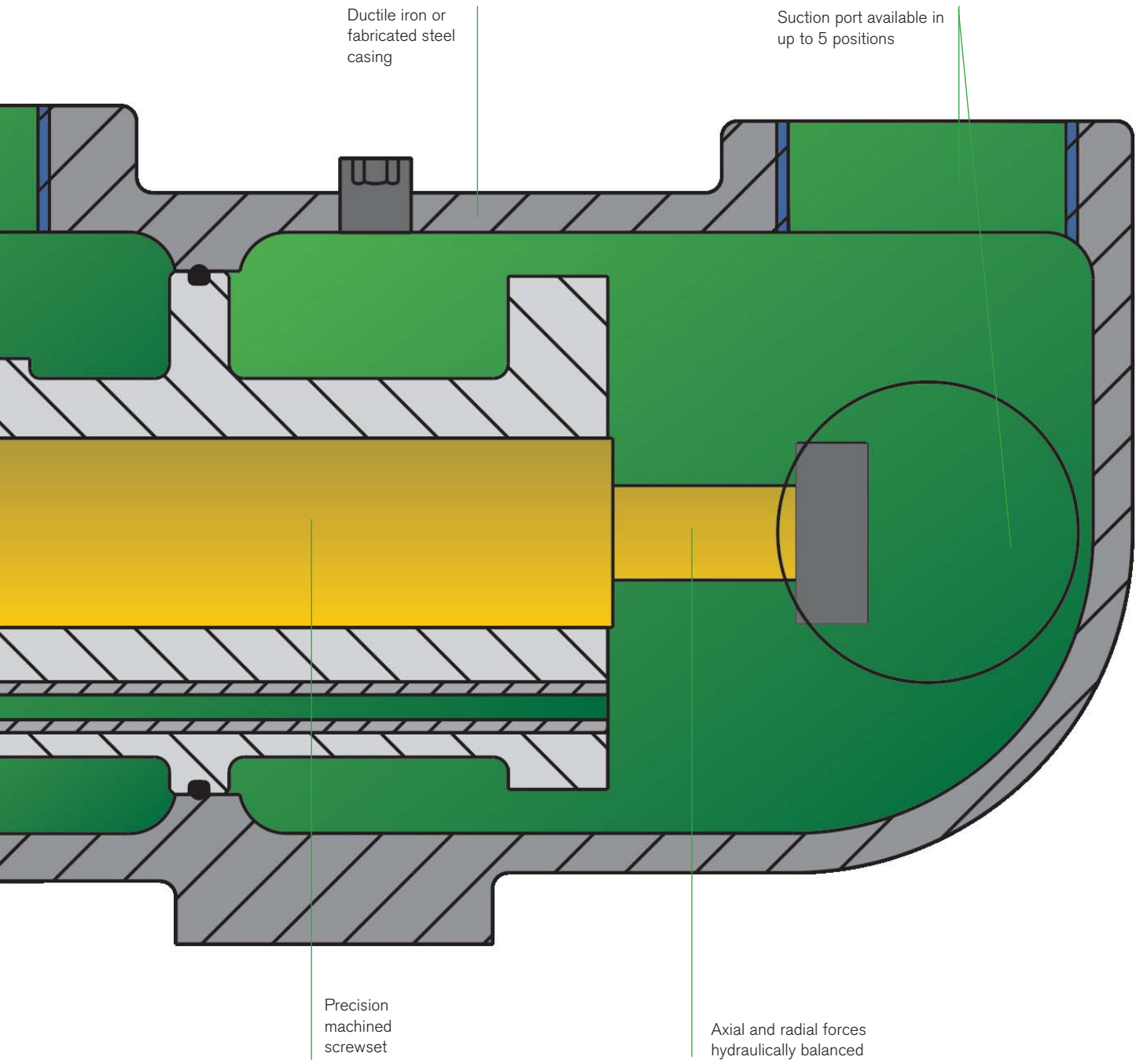

Ductile iron or
fabricated steel
casing

Suction port available in
up to 5 positions

Precision
machined
screwset

Axial and radial forces
hydraulically balanced

Technical Data

PUMP SIZE	INSERT SIZE	DISPLACEMENT PER REVOLUTION	STANDARD CAPACITY UP TO	DISCHARGE PRESSURE UP TO	STANDARD MAX RPM	STANDARD TEMPERATURE RANGE
C6 X 12	38-4 / SL	.045 LITER (.012 GAL.)	8.2 M ³ /HR (36 GPM)	50 BAR (720 PSI)	3500	-20°C (-4°F) TO 120°C (250°F)
C6 X 15	38-4 / NL	.057 LITER (.015 GAL.)	10.2 M ³ /HR (45 GPM)	41 BAR (600 PSI)	3500	
C6 X 17	45-4 / SL	.064 LITER (.017 GAL.)	13.6 M ³ /HR (60 GPM)	50 BAR (720 PSI)	3500	
C6 X 21	45-4 / NL	.079 LITER (.021 GAL.)	17.0 M ³ /HR (75 GPM)	41 BAR (600 PSI)	3500	
C6 X 30	52-4 / SL	.114 LITER (.030 GAL.)	20.9 M ³ /HR (92 GPM)	50 BAR (720 PSI)	3500	
C6 X 38	52-4 / NL	.144 LITER (.038 GAL.)	26.3 M ³ /HR (116 GPM)	41 BAR (600 PSI)	3500	
C6 X 40	60-4 / SL	.151 LITER (.040 GAL.)	32.5 M ³ /HR (143 GPM)	50 BAR (720 PSI)	3500	
C6 X 50	60-4 / NL	.189 LITER (.050 GAL.)	40.7 M ³ /HR (179 GPM)	41 BAR (600 PSI)	3500	
C6 X 65	70-4 / SL	.246 LITER (.065 GAL.)	51.6 M ³ /HR (227 GPM)	50 BAR (720 PSI)	3500	
C6 X 80	70-4 / NL	.303 LITER (.080 GAL.)	53.4 M ³ /HR (235 GPM)	41 BAR (600 PSI)	3500	
C6 X 95	80-4 / SL	.360 LITER (.095 GAL.)	76.3 M ³ /HR (336 GPM)	50 BAR (720 PSI)	2900	
C6 X 120	80-4 / NL	.454 LITER (.120 GAL.)	47.7 M ³ /HR (210 GPM)	41 BAR (600 PSI)	1750	
NOTES 1			2, 6	3, 6	2, 6	

Technical Data

PUMP SIZE	SUCTION SIZE MODEL TYPE / STYLE			DISCHARGE SIZE MODEL TYPE / STYLE		
	ALUMINUM CASE STYLE 9	DUCTILE IRON CASE STYLE 1 & 3	FAB. STEEL CASE STYLE 5	ALUMINUM CASE STYLE 8 & 9	DUCTILE IRON CASE STYLE 1 & 3	FAB. STEEL CASE STYLE 5
C6 X 12	38.1 mm (1 1/2")	50.8mm (2")	50.8mm (2")	31.75 (1 1/4")	38.1 mm (1 1/2")	38.1 mm (1 1/2")
C6 X 15	38.1mm (1 1/2")	50.8mm (2")	50.8mm (2")	31.75 (1 1/4")	38.1 mm (1 1/2")	38.1 mm (1 1/2")
C6 X 17	50.8mm (2")	63.5 mm (2 1/2")	76.2 mm (3")	38.1 mm (1 1/2")	38.1 mm (1 1/2")	50.8mm (2")
C6 X 21	50.8mm (2")	63.5 mm (2 1/2")	76.2 mm (3")	38.1 mm (1 1/2")	38.1 mm (1 1/2")	50.8mm (2")
C6 X 30	63.5 mm (2 1/2")	63.5 mm (2 1/2")	76.2 mm (3")	50.8mm (2")	50.8mm (2")	50.8mm (2")
C6 X 38	63.5 mm (2 1/2")	63.5 mm (2 1/2")	76.2 mm (3")	50.8mm (2")	50.8mm (2")	50.8mm (2")
C6 X 40	76.2 mm (3")	101.6 mm (4")	101.6 mm (4")	50.8mm (2")	63.5 mm (2 1/2")	76.2 mm (3")
C6 X 50	76.2 mm (3")	101.6 mm (4")	101.6 mm (4")	50.8mm (2")	63.5 mm (2 1/2")	76.2 mm (3")
C6 X 65	88.9 mm (3 1/2")	101.6 mm (4")	101.6 mm (4")	63.5 mm (2 1/2")	76.2 mm (3")	76.2 mm (3")
C6 X 80	88.9 mm (3 1/2")	101.6 mm (4")	101.6 mm (4")	63.5 mm (2 1/2")	76.2 mm (3")	76.2 mm (3")
C6 X 95	101.6 mm (4")	101.6 mm (4")	152.4 (6")	76.2 mm (3")	76.2 mm (3")	101.6 mm (4")
C6 X 120	101.6 mm (4")	101.6 mm (4")	152.4 (6")	76.2 mm (3")	76.2 mm (3")	101.6 mm (4")
NOTES 1		5, 6	2, 6		5, 6	

Notes:

1. Second number is displacement (theoretical capacity) per 1000 RPM. Example C6 x 12 would be 12 Gals / 1000 RPM.
2. Capacity is based on standard AC electrical motor full load RPM shown in chart. Higher speeds up to 5000 RPM may be achieved.
3. Standard Maximum Inlet Pressure is 10.3 bar (150 PSI). Optionals available for up to 20.7 bar (300 PSI) and higher.
4. Designs available up to 180°C (356 F).
5. Style 5 pumps (fabricated steel casing) are available with non-standard flange sizes.
6. Contact your local Plenty Pump representative or the factory for help with flows, pressures, temperatures, & port sizes.



Global locations

USA

SPX FLOW TECHNOLOGY

611 Sugar Creek Road
Delavan, WI 53115
United States of America
(262) 728-1900 or (800) 252-5200

EMEA

SPX EUROPE

Earl Haig Road
Hillington Business Park,
Glasgow, G52 4JN, UK
+44 141 883 0314

APAC

SPX ASIA PACIFIC

25 International Business Park
#03-03/12 German Centre
Singapore 609916
+65-6568 1570

SPX FOOD+BEVERAGE develops and implements processing technologies and other measures to help companies manage critical issues in food and beverage processing.

SPX POWER+ENERGY offers solutions for building and updating energy infrastructure, as well as for processes ranging from fuel extraction to electricity distribution.

SPX VEHICLE+TRANSIT devises products and technologies for the service and repair of automobiles and recreational vehicles, rail, heavy equipment, marine craft and mass transit.

SPX INDUSTRIAL PROCESSES creates equipment and technologies to help customers transform materials efficiently, safely and with low downtime or environmental impact.

SPX INFRASTRUCTURE serves the many market sectors involved in building and ensuring the reliability of the infrastructure, ranging from utilities to communications and broadcast.

SPX FLOW TECHNOLOGY

Earl Haig Road, Hillington Business Park,
Glasgow, G52 4JN, UK
P: +44 141 883 0314
F: +44 141 882 2752
E: plentypumps@spx.com

Your local contact:

Tapflo Makina Yapı Endüstri San. ve Dış Tic. Ltd. Şti.
Atatürk Mah. İkinci Cad. No:3 K:1 D:4 34758
Ataşehir – İstanbul TÜRKİYE
Tel: +90 216 467 33 11
Fax: +90 216 467 33 42
E-mail: sales@tapflo.com.tr
Web: www.tapflo.com.tr

SPX reserves the right to incorporate our latest design and material changes without notice or obligation.

Design features, materials of construction and dimensional data, as described in this bulletin, are provided for your information only and should not be relied upon unless confirmed in writing. Please contact your local sales representative for product availability in your region. For more information visit www.spx.com.

The green ">" is a trademark of SPX Corporation, Inc.